

# Spin & Place

## WINTER

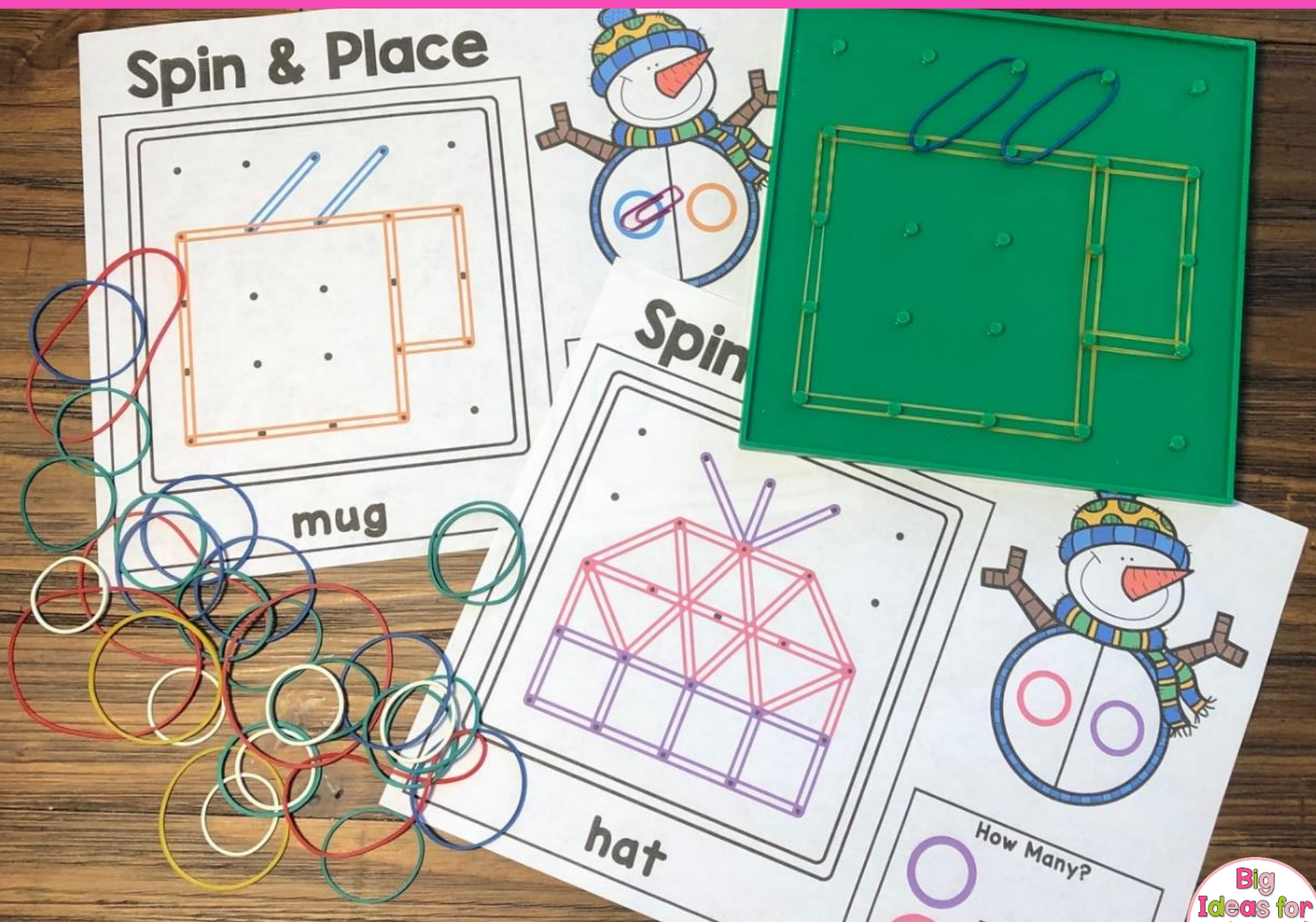

8 different designs with 2 choices for each!

# Instructions

## Easy Version

**Spin & Place**

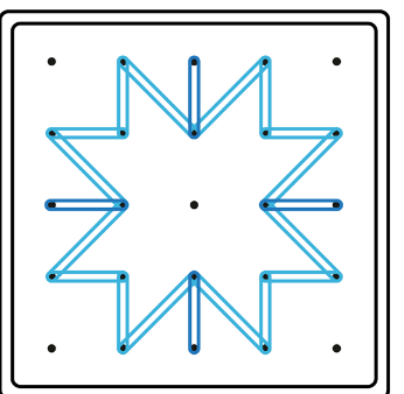

**snowflake**

How Many?

Created by Julie Davis

## Hard Version

**Spin & Place**

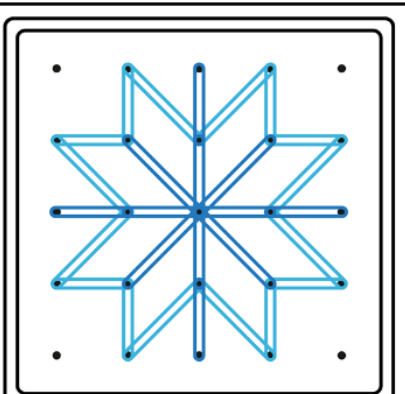

**snowflake**

How Many?

Created by Julie Davis

## Spin & Place

Students will use a spinner to spin a colored rubber band. The student will then place that colored rubber band on a geoboard to begin creating the shape in the picture.

Students will keep spinning and placing rubber bands until the picture is complete. When the mat is complete, the student will count how many of each colored rubber band and write it in the box.

# Easy Version

Spin & Place

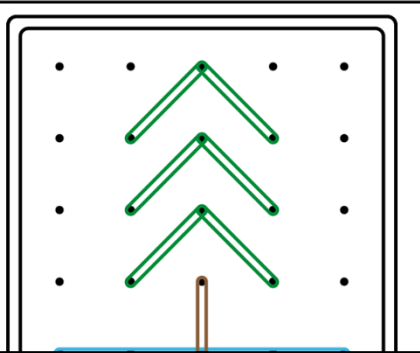

Spin & Place

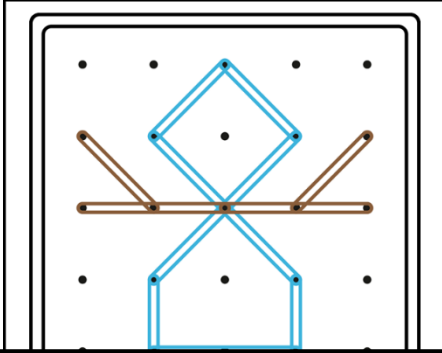

Spin & Place

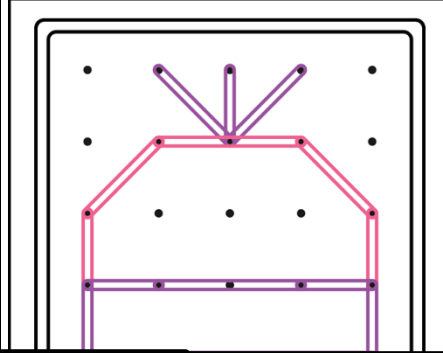

How Many?

Spin & Place

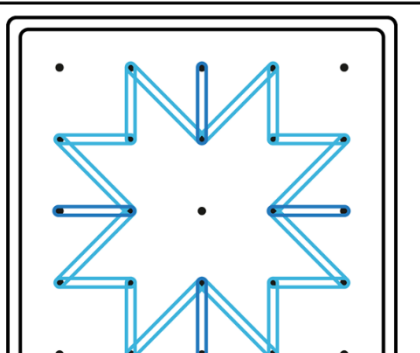

Spin & Place

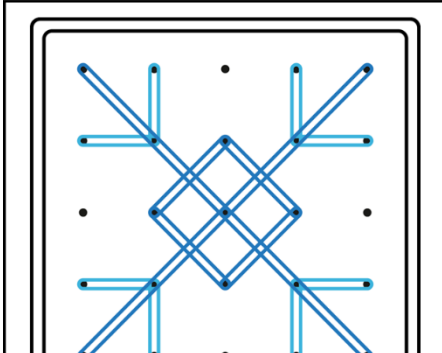

Spin & Place

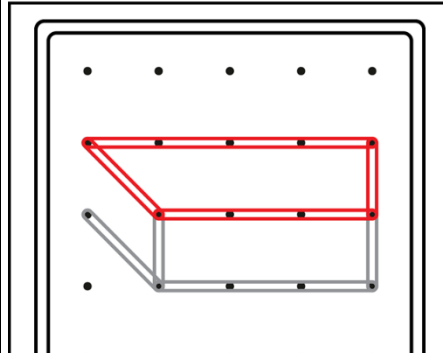

How Many?

Spin & Place

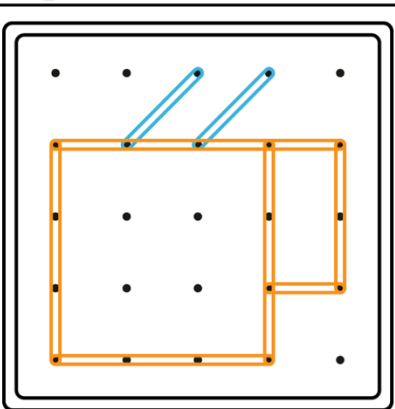

mug



How Many?

Spin & Place

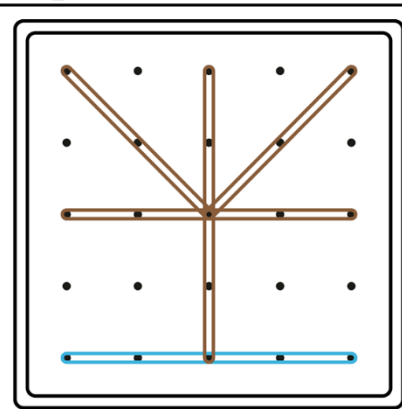

tree



How Many?

8 color images for beginners



# Hard Version

Spin & Place

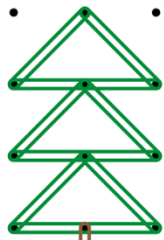

Spin & Place

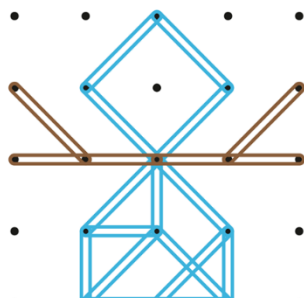

Spin & Place

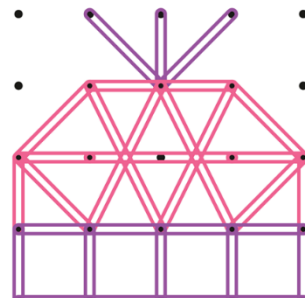

How Many?

Spin & Place

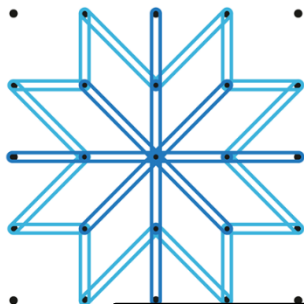

Spin & Place

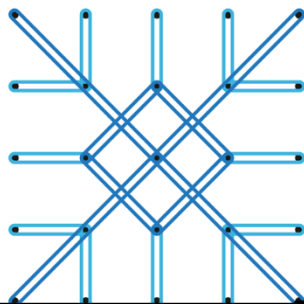

Spin & Place

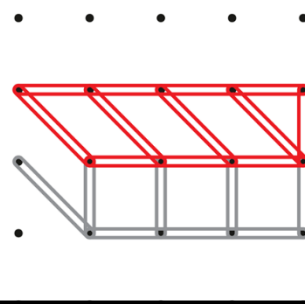

How Many?

Spin & Place

sno

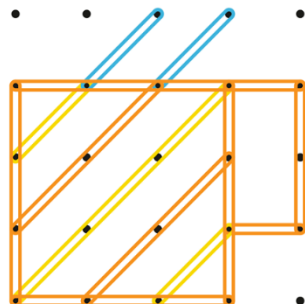

mug



How Many?

Spin & Place

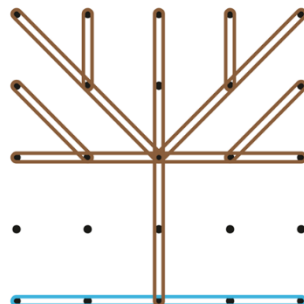

tree



How Many?

8 color images for advanced